

**MODEL 1211**

**CURRENT PREAMPLIFIER**

**DL Instruments**

Phone: (607)539-1108

Email: [info@dlinstruments.com](mailto:info@dlinstruments.com)

[www.dlinstruments.com](http://www.dlinstruments.com)

The Model 1211 Current Preamplifier was designed to provide all of the features required of a modern laboratory preamplifier. It measures current with full scale sensitivity ranging from  $10^{-2}$  to  $10^{-12}$  amperes. With a dynamic range of 96dB and output stability better than 0.003% per °C or per day plus a gain stability of 0.05% per °C of per day, its performance is unexcelled.



The classic analog design provides a clean signal without the high frequency “hash” encountered with microprocessor based designs employing multiplexed front panel displays. The wide gain bandwidth product permits calibrated, front panel rise time settings from 10μsec to 1 second.

The 1211 has a 600Ω output, a 50Ω output and a zero Ω unity gain (converter) output. It may be gated off and on by a TTL Level Pulse at a rear panel connector at a rate up to 5 kHz for input overload suppression, etc.

Other convenience features include a 0-5 volt adjustable detector bias supply with 100ppm per °C stability and calibrated current suppression of  $10^{-3}$  to  $10^{-10}$  amperes in 8 ranges.

The unit may be battery operated with the addition of the Option 10 Battery Pack. This allows the unit to run on batteries only, line power only, or while recharging from the line. Fast charge and trickle charge rates are switch selectable. External battery modification option M104 is also available so customer may use their own DC power supply to power the unit.

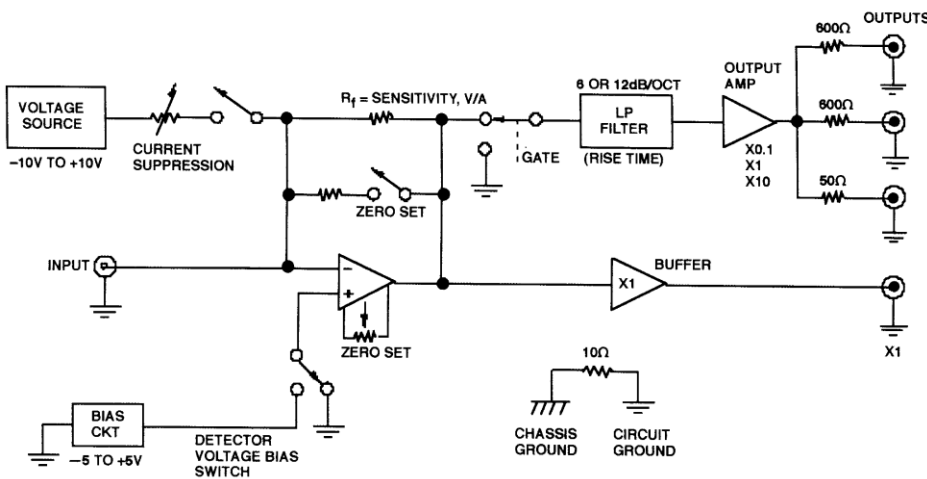

*1211 Block Diagram*

For applications information, refer to IAN 50 “Noise analysis and gain considerations in selecting the right current preamplifier” and IAN 55 “Applying the

Model 1211 current preamplifier to tunneling microscopy.” in application notes section of this website.

## **SPECIFICATIONS**

(Maximum or minimum as applicable unless otherwise noted)

**SENSITIVITY.**  $10^{-3}$  to  $10^{-11}$  ampere/volt with nine decade current gain ranges.

**GAIN MULTIPLIER** Output gain multiplier varies sensitivity in 3 steps, X0.1, X1.0 and X10, for optimum dynamic range and overload capability.

**GAIN ACCURACY**  $\pm 2\%$  of reading ( $10^{-3}$  to  $10^{-9}$  ampere/volt ranges);  $\pm 3\%$  of reading ( $10^{-9}$  thru  $10^{-11}$  ampere/volts ranges)

**INPUT OFFSET CURRENT** Less than  $0.5 \times 10^{-13}$  ampere @  $50^\circ\text{C}$ . Typically  $1 \times 10^{-14}$  @  $25^\circ\text{C}$ .

**INPUT VOLTAGE DROP** Less than 200 micro volts,  $10^{-5}$  to  $10^{-11}$  ampere/volt ranges.

**RISE TIME (Low Pass Filter)** Front panel adjustable from 10 microseconds to 1 second in a 1-3-10 sequence; MIN position rise time is less than 5 microseconds. Standard rolloff is 12 dB /octave. Jumper option for 6 dB/oct when 1211 is applied in feedback control loops.

**OUTPUT.** Four outputs (BNC) as follows:

- a)  $600\Omega$  outputs (2)
- b) Lo-Z output (to 25mA,  $50\Omega$ )
- c) Unity gain output (X1)

**OUTPUT LEVEL** 22Vpp into 1 K load (Lo-Z out)

**OUTPUT POLARITY** Unity gain (X1) Non inverted  
Lo-Z (50Ω) Inverted  
600Ω Inverted

**OUTPUT STABILITY** Output voltage offset stability better than 0.003% per °C

**ZERO SET** Input offset nulling. Used to adjust for precisely zero bias voltage on detectors such as photovoltaic diodes. Alternatively, can adjust for zero d.c. offset on output.

**CURRENT SUPPRESSION**  $10^{-3}$  ampere to  $10^{-10}$  ampere with eight decade ranges: front panel vernier (10-turn) allows a continuous suppression with 0.1% resolution. Stability is better than 0.02%/ °C or day ( $10^{-3}$  to  $10^{-8}$  ampere); better than 0.2%/ °C or day ( $10^{-9}$  to  $10^{-10}$  ampere).

**DETECTOR BIAS** Zero to  $\pm 5$  volts, adjustable and polarity- selectable with rear panel vernier (10-turn) and switch. Stability is 100ppm/°C

**GATING** TTL-compatible logic 0 or switch closure to ground (rear panel BNC input) provides gated operation of preamplifier signal path; maximum gating frequency is 5 kHz.

**POWER** 100 to 130 or 200 to 260 VAC (switch selectable), 50-60 Hz, 10 watts.

**DIMENSIONS** 90×242×385 (3.5 inch high × 9.5 inch wide ×15 inch deep)

**WEIGHT:** 3.7kg (8 lb 2oz) less Battery pack

**OPPORATING TEMPREATURE** 5 °C to 50 ° C.

**1211 RISE TIME, DYN RANGE, INPUT Z AND B.W.**

Sensitivity (A/V)	Minimum Rise Time μ Sec	Dynamic Range <sup>1</sup> dB (SNR)	Input Resistance Ohms	3dB BW <sup>2</sup> kHz
10 <sup>-3</sup>	10	96 (63000)	0.5	60
10 <sup>-4</sup>	10	96 (63000)	0.5	50
10 <sup>-5</sup>	10	96 (63000)	2	45
10 <sup>-6</sup>	15	88 (25000)	20	30
10 <sup>-7</sup>	25	78 (8000)	200	25
10 <sup>-8</sup>	40	68 (2500)	2K	13
10 <sup>-9</sup>	250	62 (1250)	20K	4
10 <sup>-10</sup>	450	55 (560)	200K	.8
10 <sup>-11</sup>	1100	48 (250)	2M	.4

1. Dynamic Range values are given with gain multiplier settings of X1 and rise time control set to min. It equals to ratio of greatest peak-to-peak signal output (at least 22 Vpp) to specified maximum wideband output noise with 100pF input shunt capacitance.

2. Measured at 50Ω or 600Ω output.

### NOISE PERFORMANCE, REFERRED TO INPUT <sup>3</sup>

Sensitivity A/V	Limited BW Noise at indicated Rise time settings <sup>4</sup>		Min. Rise Time full BW Noise <sup>4</sup> A rms	Spectral Noise Density A rms/ $\sqrt{\text{Hz}}$
	A rms	Msec		
$10^{-3}$	$2 \times 10^{-9}$	0.1	$50 \times 10^{-9}$	$75 \times 10^{-12}$
$10^{-4}$	$2 \times 10^{-9}$	0.1	$5 \times 10^{-9}$	$7.5 \times 10^{-12}$
$10^{-5}$	$200 \times 10^{-12}$	0.1	$500 \times 10^{-12}$	$1 \times 10^{-12}$
$10^{-6}$	$30 \times 10^{-12}$	0.1	$150 \times 10^{-12}$	$200 \times 10^{-15}$
$10^{-7}$	$8 \times 10^{-12}$	0.1	$40 \times 10^{-12}$	$60 \times 10^{-15}$
$10^{-8}$	$700 \times 10^{-15}$	1	$15 \times 10^{-12}$	$15 \times 10^{-15}$
$10^{-9}$	$60 \times 10^{-15}$	1	$3 \times 10^{-12}$	$5 \times 10^{-15}$
$10^{-10}$	$4 \times 10^{-15}$	10	$600 \times 10^{-15}$	$2.5 \times 10^{-15}$
$10^{-11}$	$1 \times 10^{-15}$	300	$150 \times 10^{-15}$	$1.5 \times 10^{-15}$

3. Noise at X1 gain multiplier setting using 50Ω or 600Ω output. For  $10^{-3}$  to  $10^{-5}$  sensitivity, the noise would be substantially lower using the direct 1X buffered output.

4. Broadband noise measured with 100 pF input shunt capacitance.

## TYPICAL OVERSHOOT VS INPUT SHUNT CAPACITANCE

Sensitivity A/V	Capacitance pf	Overshoot on Step Input
$10^{-3}$	33,000	6%
$10^{-4}$	10,000	2%
$10^{-5}$	5700	10%
	4300	4%
	3200	2%
$10^{-6}$	1000	4%
	500	0%
$10^{-7}$	500	8%
	350	4%
$10^{-8}$	220	20%
	110	10%
$10^{-9}$	330	14%
	110	0%
$10^{-10}$	500	6%
	225	0%
$10^{-11}$	225	6%
	150	2%

# MODEL 1211 FREQUENCY RESPONSE

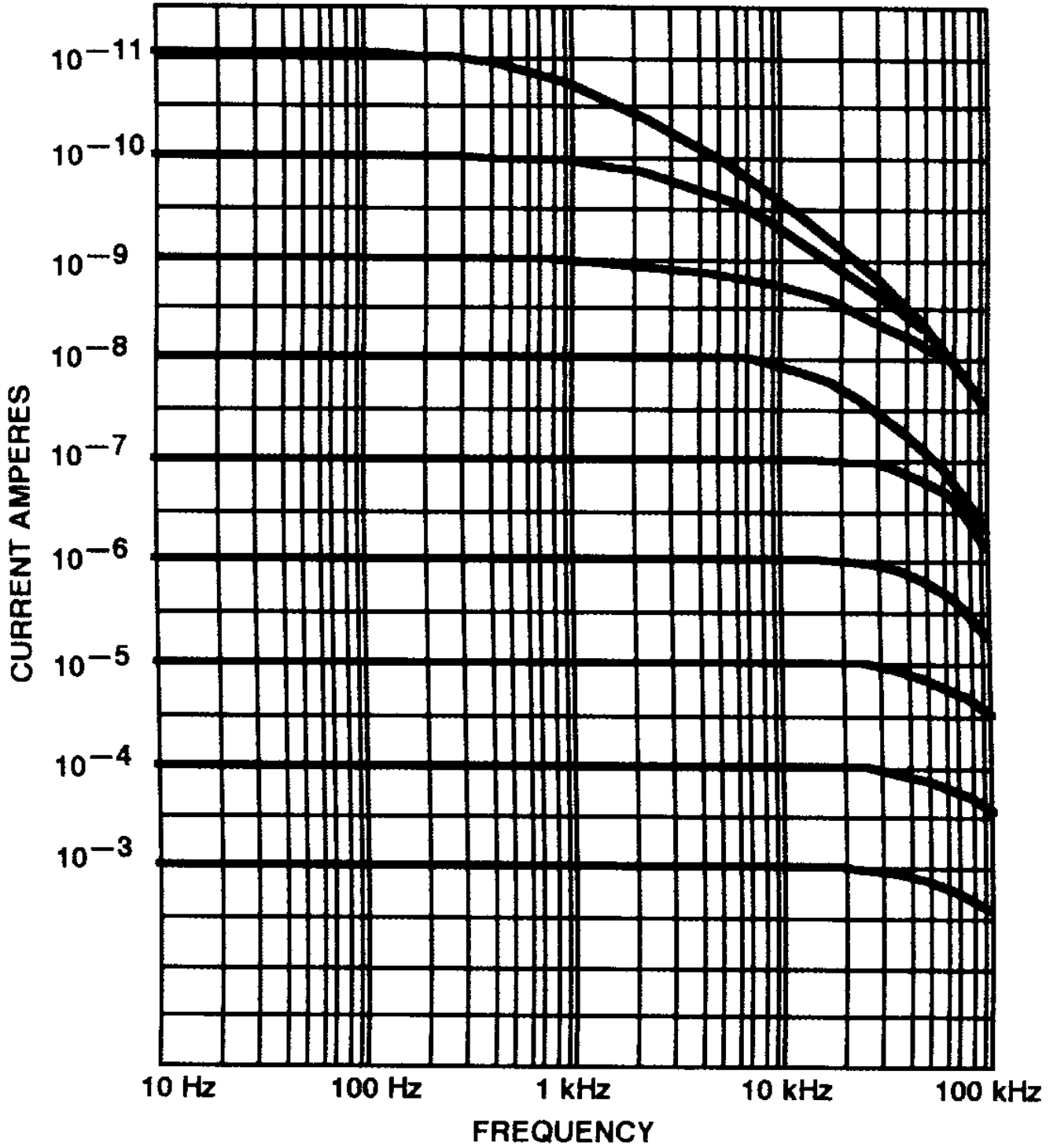



## **1211 OPTION 10 BATTERY PACK**

The retrofittable Nickel Cadmium Battery Pack installs inside the chassis, and is charged from 1211 power supply.

Battery charge time ( fast charge) < 15 hours

Battery operation time >25 hours

Weight 1.2kg ( 2 lb. 10 oz)

Option M104 is for external battery modification. In this operation the unit can switch to either powered normally or by external battery.

**For more information please contact:**

**DL INSTRUMENTS LLC  
646 76 Road  
Brooktondale, NY 14817  
USA**

**Phone: (607)539-1108**

**Email: [info@dlinstruments.com](mailto:info@dlinstruments.com)**

 **Instruments**  
[www.dlinstruments.com](http://www.dlinstruments.com)